

# SX2-D7-4.8

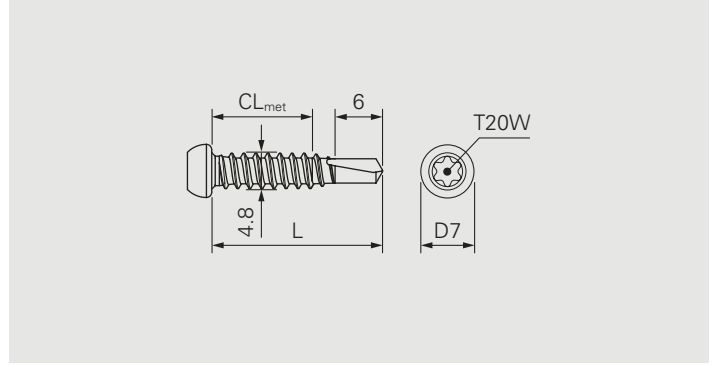

## Application

Fastening of flashings onto sandwich panels  
 Fastening of flashings onto metal profile sheets  
 Fastening of overlaps of metal profile sheets

## Component 1 (t<sub>I</sub>)

Steel 0.40–1.50  
 Steel 2×0.40–0.88  
 Aluminium 1.0–2.0

## Component 2 (t<sub>II</sub>)

Steel 0.40–1.50  
 Steel 2×0.40–0.88  
 Aluminium 1.0–2.0

## Σ<sub>max</sub> t<sub>I</sub>+t<sub>II</sub>

3.0  
 3.50  
 4.0

## Fastener material

Austenitic stainless steel A2, hardened drill point

## Approvals



## Features and Benefits

- Fast and safe self-drilling fastener instead of time consuming riveting
- Aesthetical fastening given by small D7 head shape
- Perfect fit with colored fasteners thanks to special T20-drive

## Documentation

Approval document (ETA) | Declaration of performance (DoP)

All measures in mm

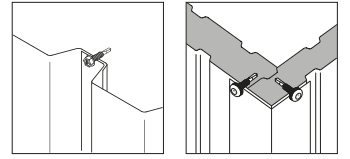

## Fastener in A2 onto steel

Product code	PU	L	CL <sub>met</sub>	
SX2-D7-4,8x22	500	22	0-9	1747715
SX2-D7-4,8x22	100			1747691

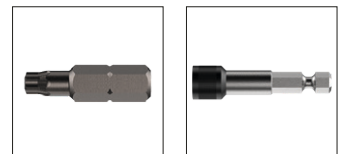

## Accessories/Ancillaries

Product code	PU	Drive	Head drive	
T20W-25-HEX $\frac{1}{4}$ "	10	$\frac{1}{4}$ "	T20W	895280
Bit holder ZA $\frac{1}{4}$ "	1		$\frac{1}{4}$ "	1162306

### All measures in mm

All information is non-binding and without guarantee. Before using the products, all specifications and calculations must be checked by a suitably qualified person and local regulations must be observed. This document is subject to revision. We reserve the right to make technical changes.