

SX16-5.8

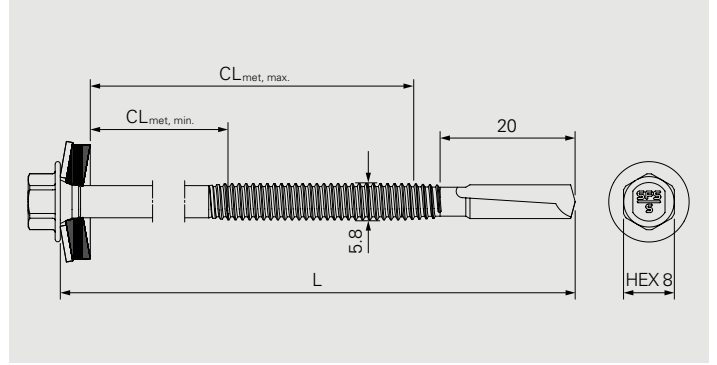
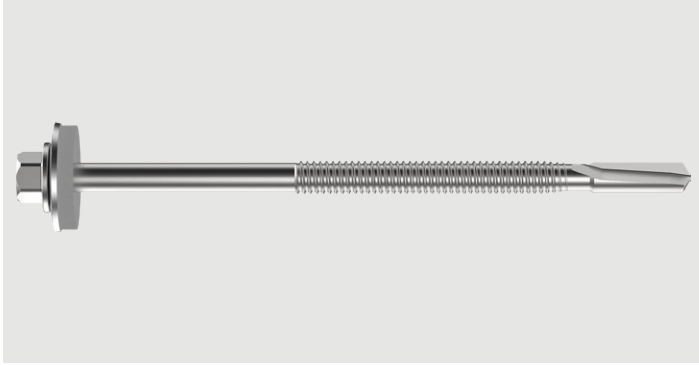

Application

Fastening of sandwich panels onto metal beams
Fastening of profile sheets onto metal beams

Component 1 (t_I / t_{NII})

Sandwich panel ≥ 0.40

Component 2 (t_{II})

Steel 3.0–14.0

$\Sigma_{\max} t_I + t_{II}$

16.0

Fastener material

Austenitic stainless steel A4, hardened drill point
Sealing washer: Austenitic stainless steel A4, EPDM-seal

Approvals

ETA-13/0183

Features and Benefits

- Self drilling fastener suitable for installation of sandwich panels
- High quality EPDM sealing washer for long-term weather sealing
- Perfect supporting of the sandwich panel outer-skin given by support thread with cut-off thread-end
- Optimized support function achieved by engineered double support thread
- High performance drill point for heavy steel beams
- High bending capacity for absorption of thermal expansion of the sandwich panel outer-skin
- High tension resistance achieved by optimized fastener geometry
- Economical benefits given by less fastener needed and installation time savings

Documentation

Approval document (ETA) | Declaration of performance (DoP)

All measures in mm

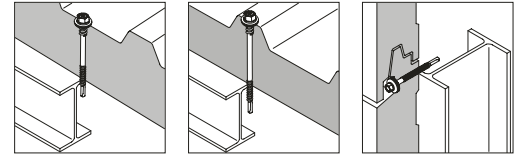

Fastener in A4 onto steel

Product code	PU	L	CL _{met}	t _{fix, met}	S16	S19
SX16-S19-5,8×90-A4	100	90	30-58	30-44/55	1639377	1649711
SX16-S19-5,8×110-A4		110	40-78	40-64/75	1649697	1649712
SX16-S19-5,8×130-A4		130	50-98	50-84/95	1649698	1649713
SX16-S19-5,8×150-A4		150	70-118	70-104/115	1649700	1679714
SX16-S19-5,8×170-A4		170	90-138	90-124/135	1649703	1649715
SX16-S19-5,8×200-A4		200	110-168	110-154/165	1649704	1649716
SX16-S19-5,8×230-A4		230	140-198	140-184/195	1649705	1649717
SX16-S19-5,8×260-A4		260	170-228	170-214/225	1649709	1649718

t_{fix, met}: CL_{met, min.} - (CL_{met, max.} - t_{II, max.} or load-bearing clamping length according ETA)/(CL_{met, max.} - t_{II, min.})

Fastener in A4 onto steel

Product code	PU	L	CL _{met}	t _{fix, met}	No washer
SX16-5,8×90-A4	100	90	30-58	30-44/55	1649686
SX16-5,8×110-A4		110	40-78	40-64/75	1649687
SX16-5,8×130-A4		130	50-98	50-84/95	1649688
SX16-5,8×150-A4		150	70-118	70-104/115	1649690
SX16-5,8×170-A4		170	90-138	90-124/135	1649691
SX16-5,8×200-A4		200	110-168	110-154/165	1649692
SX16-5,8×230-A4		230	140-198	140-184/195	1649694
SX16-5,8×260-A4		260	170-228	170-214/225	1649695

t_{fix, met}: CL_{met, min.} - (CL_{met, max.} - t_{II, max.} or load-bearing clamping length according ETA)/(CL_{met, max.} - t_{II, min.})

Accessories/Ancillaries

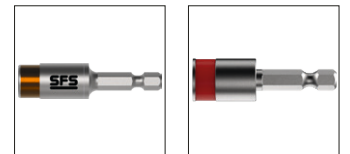

Product code	PU	Drive	Head drive	
SOK-IT-¼"-57-8Nm	1	¼"	SW8	1667322
E308-¼"-50			HEX8	1646160

All measures in mm

All information is non-binding and without guarantee. Before using the products, all specifications and calculations must be checked by a suitably qualified person and local regulations must be observed. This document is subject to revision. We reserve the right to make technical changes.