

SW3-H15-6.5

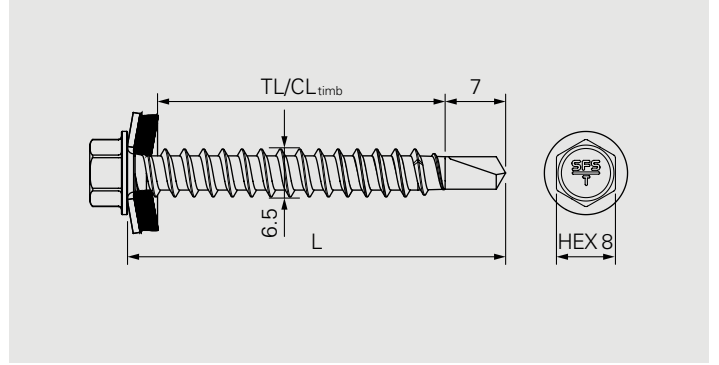
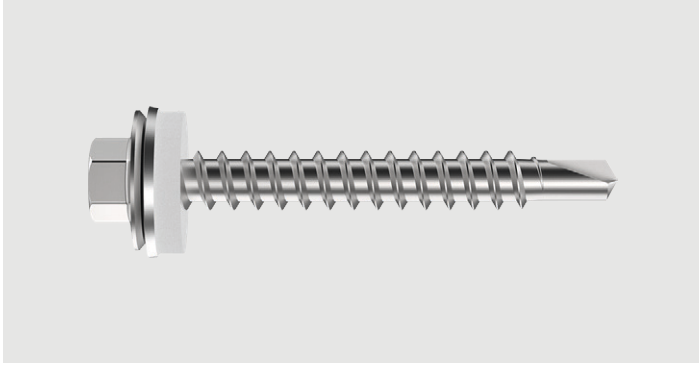

Application

Fastening steel profiles to wooden components
 Recommendation: Carbon steel fasteners should only be used in non-weathered areas.

Component 1 (t_I)

Steel	2x1.25
Aluminium	2x1.25

Component 2 (t_{II})

Timber	≥42.0
--------	-------

Fastener material

Carbon steel, Durocoat® 480
 Sealing washer: Carbon steel galvanized, EPDM-seal

Approvals



Features and Benefits

- Self drilling fastener for fastening steel profiles
- High-quality EPDM sealing washer for permanent tightness
- Reduced splitting tendency in timber thanks to drill point
- High corrosion resistance due to special galvanic coating

Documentation

Approval document (ETA) | Declaration of performance (DoP)

All measures in mm

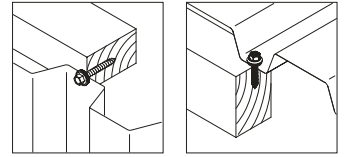

Fastener in carbon steel onto timber

Product code	PU	L	TL	CL _{timb}	t _{fix, timb}	H15
SW3-T-T16-6.5x50	250	50	39	–	0–5	71056

t_{fix, timb}: CL_{timb, min.} – (CL_{timb, max.} – l_{ef, min.})



Accessories/Ancillaries

Product code	PU	Drive	Head	
E308-¼"-50	1	¼"	SW8	1646160

All measures in mm

All information is non-binding and without guarantee. Before using the products, all specifications and calculations must be checked by a suitably qualified person and local regulations must be observed. This document is subject to revision. We reserve the right to make technical changes.